

## LED Driver

### Description

U6795B-D is an LED driver optimized for high-speed-data transmission applications up to 220 MB/s. The maximum output current is 100 mA. Output current can

be set from 25 mA to 100 mA by an external resistor at the BIAS pin. An INH pin is available for gating of the output signal.

### Features

- Data rates up to 220 MB/s
- 1 ns rise and fall time
- High current (50 mA) source capability (100 mA with additional cooling)
- 100-ps rise and fall time match
- ECL inputs
- Programmable output current allows compatibility with most LEDs
- Single supply operation
- Output inhibit control
- Available in SO-16 package or in chip form

### Block Diagram

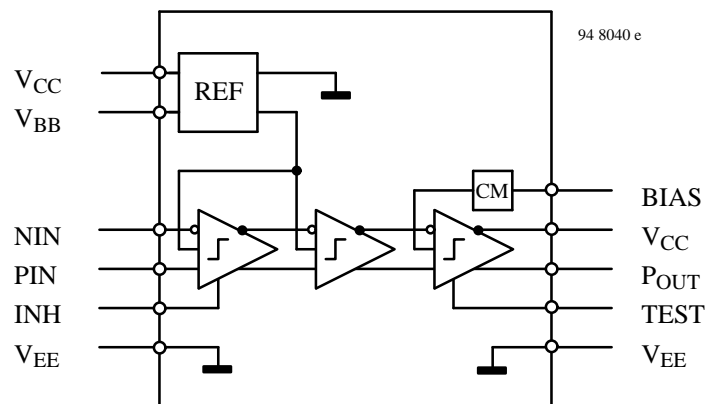

## Pin Description

Pin	Symbol	Function
1, 2	$V_{EE}$	Negative supply voltage
3	BIAS	LED current programming pin
4	$V_{BB}$	Reference voltage for asymmetric input signals
5, 6	PIN, NIN	Differential ECL input
7, 8	$V_{EE}$	Negative supply voltage
9	INH	Disables the output when hold high
10	TEST	Indirect testing of the output signal
11, 12	OUT	Output
13, 16	$V_{CC}$	Positive supply voltage, normally grounded

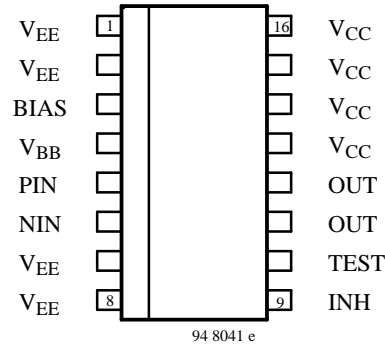

## Absolute Maximum Ratings

Parameters	Symbol	Value	Unit
Supply voltage Pins 1, 2, 7 and 8	$V_{EE}$	6.0	V
Input voltage Pins 3, 5, 6 and 9	$V_i$	$V_{EE}$ to GND	V
Junction temperature	$T_j$	125	°C
Storage temperature range	$T_{stg}$	-40 to +125	°C

## Operating Range

Parameters	Symbol	Value	Unit
Ambient temperature range	$T_{amb}$	-40 to +70	°C

## Thermal Resistance

Parameters	Symbol	Value	Unit
Junction ambient SO-16	$R_{thJA}$	typ. 120	K/W

## DC Electrical Characteristics

Operating conditions:  $T_{amb} = 0^{\circ}\text{C}$  to  $70^{\circ}\text{C}$ ,  $V_{EE} = -5.2\text{V} \pm 10\%$

Parameters	Test Conditions / Pins	Symbol	Min.	Typ.	Max.	Unit
Supply voltage	Pins 1, 2, 7 and 8	$V_{EE}$	4.5		5.7	V
Supply current	$I_{LED} = 50\text{ mA}$	$I_{EE}$	-100	-91		mA
LED output current *	$R_{BIAS} = 820\ \Omega$	$I_{OH}$			50	mA
Low level output current		$I_{OL}$			1	mA
High level input current	(PIN, NIN, INH)	$I_{IH}$			250	$\mu\text{A}$
Low level input current	(PIN, NIN, INH)	$I_{IL}$			100	$\mu\text{A}$
High level input voltage		$V_{IH}$	-0.98		-0.7	V
Low level input voltage		$V_{IL}$	-1.82		-1.62	V

\* For  $I_{LED} \geq 50\text{ mA}$  an additional heatsink is required.

## AC Electrical Characteristics

Operating conditions:  $T_{amb} = 0^{\circ}\text{C}$  to  $70^{\circ}\text{C}$ ,  $V_{EE} = -5.2\text{V} \pm 10\%$

Parameters	Test Conditions / Pins	Symbol	Min.	Typ.	Max.	Unit
Output rise time	$R_L = 10 \Omega$ at OUT	$t_r$	0.6		1.2	ns
Output fall time	$R_L = 10 \Omega$ at OUT	$t_f$	0.6		1.2	ns
Propagation delay time		$t_{pd}$	2		4	ns
Bandwidth		BW	200			MHz

## Functional Description

U6795B-D transforms an ECL level digital input into a signal which is optimal for driving LEDs. It contains a proprietary high-speed driver and a high-current switch.

The steady-state forward current flowing through an LED is directly proportional to the light it produces. When the U6795B-D is used in a typical configuration, the steady state forward current in the LED is:

$$I_{LED}/\text{mA} = 17 * \frac{V_{EE}/V - 1.7}{300 + R_{BIAS}/\Omega}$$

The actual forward current produced is affected by  $V_{EE}$ ,

$R_{BIAS}$ , the temperature of the part and the  $\pm 20\%$  tolerance of the internal  $300 \Omega$  resistance.

In order to reduce ringing and self-oscillation after turning on the LED, the output current switch incorporates a negative feedback and a damping network. Therefore the inductive load (signal path plus internal inductivity of the LED) may be up to 7 nH.

For asymmetrical input operation VBB has to be connected to NIN.

The LED current can also be controlled via a voltage applied to the bias pin.

## Typical Application

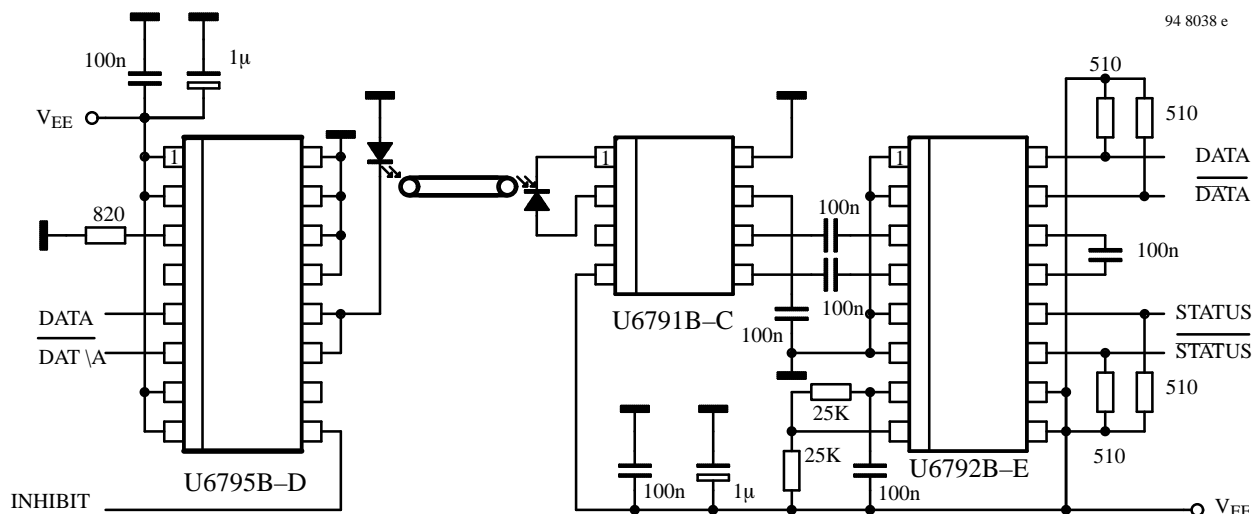

## Typical Characteristics ( $T_{amb}$ 25°C unless otherwise noted)

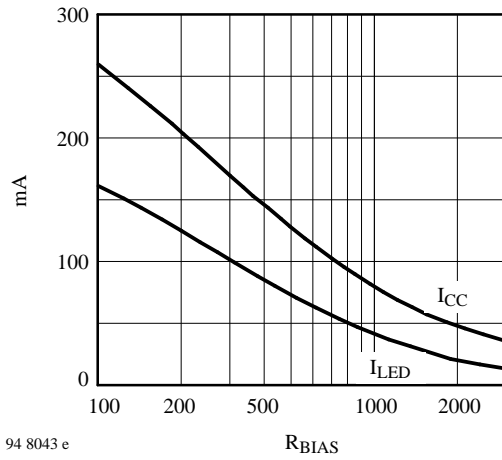

Figure 1.  $I_{CC}$  and  $I_{LED}$  vs.  $R_{BIAS}$

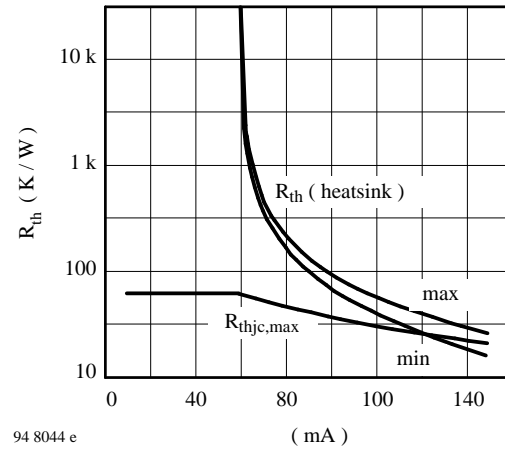
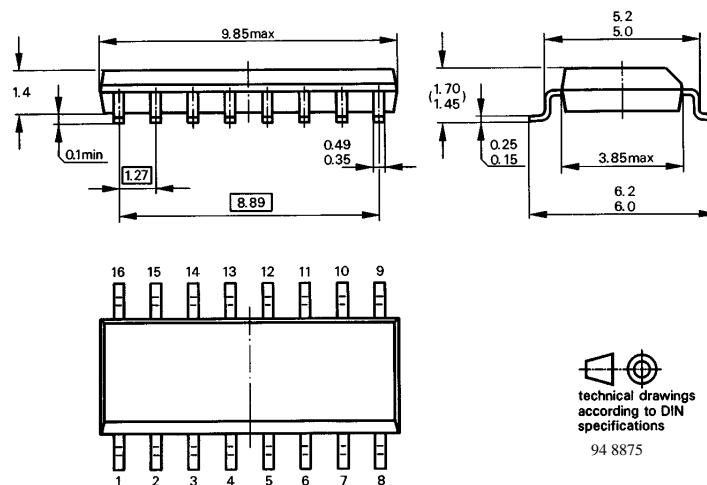

Figure 2.  $R_{th}$  vs.  $I_{LED}$

## Dimensions in mm

SO 16



## Ozone Depleting Substances Policy Statement

It is the policy of **TEMIC TELEFUNKEN microelectronic GmbH** to

1. Meet all present and future national and international statutory requirements.
2. Regularly and continuously improve the performance of our products, processes, distribution and operating systems with respect to their impact on the health and safety of our employees and the public, as well as their impact on the environment.

It is particular concern to control or eliminate releases of those substances into the atmosphere which are known as ozone depleting substances (ODSs).

The Montreal Protocol (1987) and its London Amendments (1990) intend to severely restrict the use of ODSs and forbid their use within the next ten years. Various national and international initiatives are pressing for an earlier ban on these substances.

**TEMIC TELEFUNKEN microelectronic GmbH** semiconductor division has been able to use its policy of continuous improvements to eliminate the use of ODSs listed in the following documents.

1. Annex A, B and list of transitional substances of the Montreal Protocol and the London Amendments respectively
2. Class I and II ozone depleting substances in the Clean Air Act Amendments of 1990 by the Environmental Protection Agency (EPA) in the USA
3. Council Decision 88/540/EEC and 91/690/EEC Annex A, B and C (transitional substances) respectively.

**TEMIC** can certify that our semiconductors are not manufactured with ozone depleting substances and do not contain such substances.

**We reserve the right to make changes to improve technical design and may do so without further notice.**

Parameters can vary in different applications. All operating parameters must be validated for each customer application by the customer. Should the buyer use TEMIC products for any unintended or unauthorized application, the buyer shall indemnify TEMIC against all claims, costs, damages, and expenses, arising out of, directly or indirectly, any claim of personal damage, injury or death associated with such unintended or unauthorized use.

TEMIC TELEFUNKEN microelectronic GmbH, P.O.B. 3535, D-74025 Heilbronn, Germany  
Telephone: 49 (0)7131 67 2831, Fax number: 49 (0)7131 67 2423